

**Description:**

The Sylax® butterfly valve is a resilient-seated valve designed for many general industrial service applications including commercial, irrigation and municipal usage. The butterfly valve is composed of body, shaft, disc, seat, bushing, shaft bearings, manual operator, etc. The manual operator drives the shaft and disc to open/close the valve and control the flow.

Manufactured in lugged or wafer style cast iron body, the Stainless Steel or Nylon coated Ductile Iron disc and EPDM liner are standard materials. We also offer NBR and Viton liners (consult factory for availability). The standard valve ratings are listed below:

Standards / Ratings:

Nominal Diameters	2" (50mm) THRU 12" (300mm)
Max Working Temperature	230° F (110° C)
Max Pressure	200 psi (14 bar)
Flanges Rating	ANSI 125 (B16.1)
Top Mounting	ISO 5211

- The product complies with the requirements of BS5155: 1984 (butterfly valves).
- Low Lead Certified according to NSF/ANSI 372

OPTIONAL OPERATED METHODS:

- Lever operated: depress the lever and turn it clockwise or counter-clockwise up to 90° then release the lever. (There are 10 locking positions between and including 0° and 90°)
- Gear operated: turn the hand wheel to drive the disc to the closed position and control the flow. To close the valve turn the hand wheel clockwise.
- Actuator operated

FEATURES:

- Small in size and light in weight. Easy installation and maintenance, versatile installation.
- Simple and compact construction. Quick 90° on-off operation.
- Minimized operating torque, energy saving.
- Bubble-tight shut off.
- Wide selection of materials, applicable for various media.
- Flow curve modified linear, excellent regulation performance.
- Extended service, high cycle life.
- The pipeline installed with gate valve, plug valve, rubber pipe valve or diaphragm valve etc. can be replaced by a butterfly valve and a short joint (spool piece), details as per the sketch.

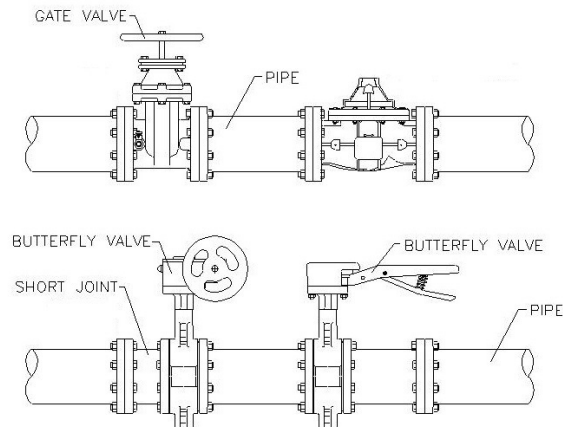

High Quality Valves Built to Last...

Flomatic Corp, 15 Pruyn's Island, Glens Falls, New York 12801
 Phone: 518-761-9797 Fax: 518-761-9798 www.flomatic.com

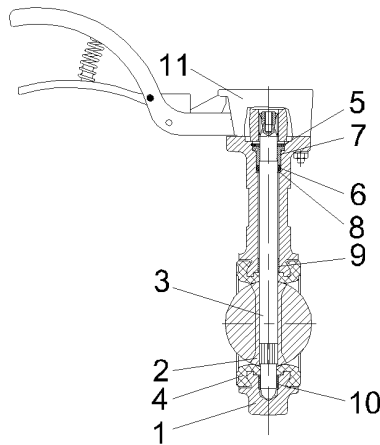

1	BODY
2	DISC
3	SHAFT
4	LINER
5	CIRCLIP
6	O'RING
7	BUSHING
8	SAFETYBUSHING
9	UPPER BUSHING
10	LOWER BUSHING
11	LEVER ASSEMBLY

SHIPMENT / STORAGE / INSTALATION:

- Sylax® butterfly valves disc should be opened no more then 4 to 5 degrees during storage or transportation. This is to protect the disc edge from damage.
- Sylax® butterfly valves should be stored in a clean, dry place away from uv light.
- Prior to installation verify:
 - That the Sylax® butterfly valve selected is correct for the application.
 - That all sealing surfaces are clean, and free from debris.
 - That all scale, debris, foreign materials are removed from piping system.
 - That valve operator (lever, gear or actuator) is properly secured to valve.
 - That Sylax® butterfly valve disc outside diameter is not greater than piping/flange inside diameter. If it is valve will not open properly and you may “jam” disc inside piping/flange damaging valve disc.
- The Sylax® butterfly valve can be installed in any orientation in pipeline.
- Flow through the Sylax® butterfly valve can be bi-directional.
- Position of Sylax® butterfly valve in piping system should allow for ease of operation, maintenance and removal.
- Mounting wafer style Sylax® butterfly valves to the pipeline flanges can be done with either bolts or studs that extend through both flanges
- Mounting lug style Sylax® butterfly valves to the pipeline flanges should be done with bolts only. Studs are not recommended.
- During installation verify:
 - The piping alignment to Sylax® butterfly valve is correct.
 - The Sylax® butterfly valve disc is open partially inside the valve body. Disc should not be in full closed position when tightening flanges. This allows rubber seal to self position for proper seal to disc interaction.
 - A flange gasket is not used between the Sylax® butterfly valve and the pipe flange. The Sylax® butterfly valve seat / liner flange face has a molded in o’ring which provides all the valve to flange sealing necessary.
 - ***When an actuator is mounted on the Sylax® butterfly valve, the actuator should not be mounted below horizontal in order to avoid water damage to the actuator that may occur if there is condensation or a water leak that travels along the piping and into the actuator.***
 - The Sylax® butterfly disc is interference free from piping components. While flange bolting is finger tight, open disc slowly to check for interference. If no interference return disc to partial open and finish tightening flange bolts in a crisscross pattern. **If interference occurs check for piping misalignment.** After realigning piping flanges recheck for interference.
- After installation Sylax® butterfly valve disc should be in open position for initial system pressure testing.
- Recommended routine inspection checks should include:
 - Verification by visual inspection that valve seat and flange sealing surfaces are in good condition.
 - Verification that the valve operator is in working condition.
 - After inspection/maintenance verify that valve is opening and closing smoothly.
 - After inspection/maintenance verify that valve is leak tight in closed position.



High Quality Valves Built to Last...

Flomatic Corp, 15 Pruyn's Island, Glens Falls, New York 12801
 Phone: 518-761-9797 Fax: 518-761-9798 www.flomatic.com



- Wafer and lug style butterfly valves provide the same working performance. However the lug style, only can be used for "**bi-directional dead end**" service, however, pressure rating may be de-rated.

NOTE: for size and quantities of bolts see table

REMOVING VALVE FROM SYSTEM:

- **WARNING !**



Loosening the bolts on a pressurized valve/system can cause the valve to shift and release uncontrolled pipeline fluid. This will cause personal injury and/or pipeline damage.

- Relieve the pressure from the system and make sure to drain the pipeline before loosening valve bolting.
- Close the Sylax® butterfly valve disc before removing from between the pipe flanges.



If the Sylax® butterfly valve has an electric actuator make sure to turn off and lock out the power before removing or servicing.

- If the actuator is powered, disconnect and lock out any electric, pneumatic or hydraulics to prevent injury and/or accidental operation.
- Support the Sylax® butterfly valve, remove the bolts completely then remove the Sylax® butterfly valve from the pipeline.



Do not lift by the stem – this will damage the Sylax® butterfly valve and void the warranty.

TROUBLE SHOOTING:

PROBLEM	REASON	POSSIBLE SOLUTION
Valve does not fully close	Debris wedged between disc and seal or stop is not adjusted correctly	Open valve to flush out debris or adjust the close stop
Leakage at sealing surface	Seat damaged, disc damaged or dirt between disc and seat	Replace seat or disc, clean the sealing surface
Leakage at the shaft	The seat shaft hole damaged, or O-ring damaged	Replace seat or O-ring
Leakage at flange end	The bolt did not contact tightly, or not uniform, or seat damaged	Tighten bolts or replace the seat.



Warning: Working pressure, temperature, media must match valve capability or valve/piping damage can occur.

- Working pressure must not exceed valve maximum pressure rating.
- Temperature must not exceed maximum temperature rating.
- Media must be compatible with body, seat, seals and disc material.

Flomatic Valves is not responsible for the loss caused by the usage beyond the valve capabilities.

SIZE & QUANTITIES OF BOLTS FOR INSTALLATION:

SIZE		Flange 125# / 150#			
in	mm	QTY	Bolt Ø	Bolt Length	Torque (ft/lbs)
2-1/2	65	4	5/8	2-1/2	25-75
3	80	4	5/8	2-1/2	25-75
4	100	8	5/8	3	30-90
5	125	8	3/4	3	30-90
6	150	8	3/4	3-1/4	30-90
8	200	8	3/4	3-1/2	40-120
10	250	12	7/8	3-3/4	45-150
12	300	12	7/8	3-3/4	65-200

Limited One Year Warranty: Flomatic valves are guaranteed against defects of material or workmanship when used for the services recommended. If, in any recommended service a defect develops due to material or workmanship, and the device is returned, freight prepaid, to Flomatic Corporation within 12 months from date of purchase, it will be repaired or replaced free of charge. Flomatic Corporations' liability shall be limited to our agreement to repair or replacement of valve only. ©2017

High Quality Valves Built to Last...

Flomatic Corp, 15 Pruyn's Island, Glens Falls, New York 12801
 Phone: 518-761-9797 Fax: 518-761-9798 www.flomatic.com